



# Agenda

CITY CLERK'S OFFICE

DATE 10/2/13 TIME 10:05 am

SERVED BY Brian Drypolder

RECEIVED BY [Signature]

## SANTA FE RIVER COMMISSION

Thursday, October 10, 2013

6:00 p.m. – 8:00 p.m.

City Councilors' Conference Room, City Hall

200 Lincoln Avenue, Santa Fe, NM

505.955.6840

1. ROLL CALL
2. APPROVAL OF AGENDA
3. APPROVAL OF MINUTES FROM SEPTEMBER 12, 2013
4. INFORMATION/DISCUSSION/ACTION ITEMS
  - a) Information and Discussion: Regarding the activities of the artists group *Rivers Run Through Us*, and their proposal for activities focused on the Santa Fe River for 2014.
  - b) Discussion: Regarding the Santa Fe River Voluntary Conservation Fund – in particular regarding outreach to contributors to obtain consent to modify the purposes for which their contributions can be spent; and cost estimates for some of the options for projects that may be funded by the program.
6. MATTERS FROM COMMISSIONERS, MATTERS FROM SUB-COMMITTEES
7. MATTERS FROM STAFF
8. CITIZENS COMMUNICATION FROM THE FLOOR

ADJOURN

Persons with disabilities in need of accommodation, contact the City Clerk's office at 955-6520, five (5) working days prior to meeting date.

1. Roll Call	Constitutes a Quorum	Page 2
2. Approval of Agenda	<i>Ms. Romero-Pike moved to approve the agenda as presented, second by Mr. Ellenberg, motion carried by unanimous voice vote.</i>	Page 2
3. Approval of Minutes	<i>Mr. Ellenberg moved to approve the minutes as presented, second by Mr. Bové, motion carried by unanimous voice vote.</i>	Page 2
4. <i>Information/ Discussion/Action Items</i>		
a. <i>Rivers Run Through US</i>	<i>Informational, live presentation, no motion or second for action item.</i>	Page 2-3
b. <i>Santa Fe River         Voluntary Conservation         Fund</i>	<i>No formal Action</i>	Page 3-4
5. <i>Matters from Commissioners, Matters from Sub-Committees</i>	<i>Informational</i>	Page 4
6. <i>Matters from Staff</i>	<i>Informational</i>	Page 4-5
7. <i>Citizens Communication From the Floor</i>	<i>None</i>	Page 5
8. <i>Adjourn</i>	<i>Meeting was adjourned at 7:45 pm</i>	Page 5
 <i>Signature Page</i>		 Page 5

River  
Commission  
Meeting -  
Minutes

October 10  
2013

Draft Until Approved

Fran Lucero,  
Stenographer

*Fran Lucero*

**1. ROLL CALL**Present

Jerry Jacobi, Chair

Phillip J. Bové

Richard D. Ellenberg

Melinda Romero-Pike

Not Present

John R. Buchser, Excused

Dale Doremus, Excused

Sam Gerberding

Others Present

Bobbe Besold, Artist, Rivers Run Through US

Dominique Mazeaud, Artist, Rivers Run Through US

Valerie Martinez, Artist, Rivers Run Through US

Alan G. Hook, Water Resources Analyst, City of Santa Fe Water Division

Claudia Borchert, Water Resources Coordinator, City of Santa Fe Water Division

Bryan Drypolcher, Staff Liaison

Anna Serrano for Fran Lucero, Stenographer

**2. APPROVAL OF AGENDA**

*Ms. Romero-Pike moved to approve the agenda as presented, second by Mr. Ellenberg, motion carried by unanimous voice vote.*

**3. APPROVAL OF MINUTES SEPTEMBER 12, 2013**

*Mr. Ellenberg moved to approve the minutes as presented, second by Mr. Bové, motion carried by unanimous voice vote.*

**4. INFORMATION/DISCUSSION/ACTION ITEMS**

- a. Information and Discussion: Regarding the activities of the Artists group *Rivers Run Through US* and their proposal for activities focused on the Santa Fe River for 2014. (Exhibit A)

*Rivers Run Through US* is an ongoing community engagement project that utilizes is to change minds, hearts and actions. Their focus is the Santa Fe River, the river watershed and the people and riparian communities who live along the waterway.

Members of *the Rivers Run Through US* were introduced individually and Ms. Besold, Mazeaud and Martinez showed their presentation to the River Commission members. As

Artist they are non-partisan and they can bring people together in a cross over manner, going across the boundaries that divide us when it comes to working on the restoration of the river. It was noted that they were involved the first year with Cochiti Pueblo on the last day of the walk the first year. In May, 2012, the team walked the 54 miles length of the river from the Upper Watershed (closed to the public since 1927) to the confluence at the Rio Grande. This rigorous 5 day/4 night pilgrimage served as a deep experience of and homage to the river's beauty, diversity, and endangerment. In year two they completed a ten minute documentary film about the river and the May 2012 walk.

Year Three (June 2012 – May 2014)

The team will continue to initiate and encourage meetings and gatherings with individuals and organizations working on behalf of the river. They will continue public outreach/education activities. They will engage the community in the creation and installation of "Dreaming Water Houses," permanent poetry/art installations along the full length of the river. The idea is to have people walk from one dream water house to another and possibly adopt a part of the river. They will continue their efforts to create and interactive Santa Fe Riversite – website.

Mr. Ellenberg commented on the relationships with the associations and in some cases the lack of coordination amongst many of the non-profits as it relates to the Santa Fe River. It was noted that creating a river collaborative is a beautiful thing. Bringing all the voices together is a positive point for the river that we all love. Bobbe reiterated that Art has the power to bring people together. Our agenda is the health and restoration of the Santa Fe River. We believe there are different beliefs but we also feel strongly that Art can be a driving force to bring everyone together.

The Chair expressed his thanks on his behalf. A motion could not be made on the support and endorsement of the Dreaming Water Houses.

- b. Discussion: Regarding the Santa Fe River Voluntary Conservation Fund – in particular regarding outreach to contributors to obtain consent to modify the purposes for which their contributions can be spent; and cost estimates for some of the options for projects that may be funded by the program.

Contributions since March 13, 2013: \$11,220.00 (Mr. Drypolcher could not confirm that this amount includes the match amount).

Cost Estimates, constructed storm water features provided by contractor:

- Construction of "oxbow" storm water infiltration feature with curb cut and basin: \$1500
- Construction at the "storm water Acequia" – linear, stone-lined drainage/infiltration feature with capture from curb cuts: \$75 to \$100 per linear ft.

- Seeding hydro-seed with tack mulch and native seed: .20 to .50 sq. ft. or about \$8000 per acre. Mr. Drypolcher asked for this bid due to the need at the bottom of Camino Alire/Frenchy's. We are past the warranty period.

Mr. Drypolcher was not in total agreement with the above estimate for the "oxbow" and he will seek a competitive bid.

Ms. Borchert asked what the commission is trying to achieve as we are all trying to get more flow to the river. Mr. Drypolcher asked for clarification as Ms. Borchert stated, "more flow to the river" as in some cases it might end up improving the flow in the Santa Fe River as it does the eco-system. Some of these storm water interventions result in less flow in the river because we are trying to keep nasty storm water out and put it to beneficial use. Ms. Borchert stated, what the worst things are going on and where do we want to start to address them in priority.

Mr. Ellenberg said that it might behoove the commission to identify projects with the appropriate cost factors and at that time solicit the support from the public. Right now the projects above do not amount to much. Mr. Ellenberg said that it would be good to show the pictures before and after a project but he is committed to identifying a river fund project.

Mr. Drypolcher said that he has before and after pictures of many of the projects and that they have done and he is working on an RFP for some of those projects.

Mr. Drypolcher informed the commission members that as discussed at the last meeting regarding the direct mail; he is working on a professional services contract amendment to allow the Water Shed to manage this program. Mr. Drypolcher will meet with the City Attorney to assure that this mail out is approved. The same message will also be on the website. The hopes are to have the mail out done in 6 to 8 weeks.

Mr. Hook asked about the last time there was discussion on the people who had donated and asking for their feedback. Mr. Hook asked Mr. Ellenberg who he thought were the contributors as he would be in favor of waiting for additional donations. Mr. Ellenberg said that they are people who will always be steady contributors to the River Fund.

#### **5. MATTERS FROM COMMISSIONERS, MATTERS FROM SUB-COMMITTEES**

Kids Fall Fishing Derby – Saturday, October 12, 2013

7:00 am – 12:00 Noon – This was a recommended activity suggested by Councilor Trujillo. Game and Fish was able to stock 500 rainbow trout. Thank you to all the hard work by Youth Works and Chavez Security who will patrol the river until the event begins.

#### **6. MATTERS FROM STAFF**

Ms. Borchert talked about the need of a monthly report on the reservoir operations. Mr. Ellenberg stated that Robert provides his written report the second Monday of each month and this information would be useable.

**7. CITIZENS COMMUNICATION FROM THE FLOOR**

None

**8. ADJOURN**

Mr. Ellenberg moved to adjourn at 7:45 pm, second by Mr. Bové, motion carried by unanimous voice vote.

**SIGNATURE PAGE:**

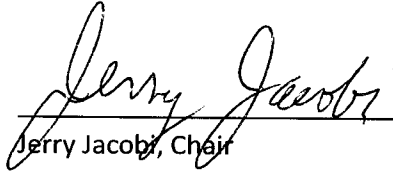
  
\_\_\_\_\_  
Jerry Jacobi, Chair

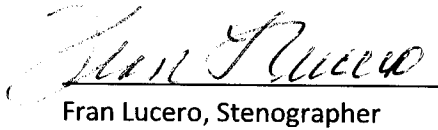
  
\_\_\_\_\_  
Fran Lucero, Stenographer



# Rivers Run Through Us

2014

[www.riversrunthroughus.net](http://www.riversrunthroughus.net)

***Rivers Run Through Us*** is an ongoing community engagement project that utilizes art to change minds, hearts and actions. Our focus is the Santa Fe River, the river watershed, and the people and riparian communities who live along the waterway.

In 2007, the **Santa Fe River** was named the most endangered river in the U.S. (*American Rivers*). Local citizens, environmental organizations, and the county and City of Santa Fe have worked to restore her. The Rivers Run Through Us project complements these efforts by cultivating the **restoration of our river communities**. The future of the river depends on deepening our **awareness**, fostering **cross-community dialogue**, and nurturing **collective efforts**.

*We know that art  
is uniquely able  
to ignite our imaginations,  
educate,  
and galvanize cooperative action.*

## ***Year Three (June 2013-May 2014)***

❖ The team will continue to **initiate and encourage meetings and gatherings** with individuals and organizations working on behalf of the river, supporting **collaborative initiatives** and **sensitive and inclusive dialogue** around competing interests.

❖ We will **continue our public outreach/education activities**--gathering stories and testimonials, disseminating information, facilitating workshops, walking --encouraging a deeper understanding of the importance of water and the Santa Fe River.

❖ We will engage the community in the creation and installation of "**Dreaming Water Houses**," permanent poetry/art installations along the full length of the river. These beautiful "signposts"--created and sponsored by individuals, organizations and businesses--will encourage citizens and visitors to gather at the river and reflect on the value of water and the reality of the river in our lives. They will also serve as conservation/restoration sites as sponsors will be asked to maintain their House and the area nearby.

❖ We will continue our efforts to create an **interactive Santa Fe Riversite**--a website that presents the river as a continuous and living entity--populated with data, art, science, history, restoration efforts, oral stories and more--allowing viewers to explore the complexities of a river system in the Southwest.

*Exhibit A*



## ***Year Two (June 2012-May 2013)***

- ❖ We completed a **ten minute documentary film** about the river and our May 2012 walk.
- ❖ We continued to **form partnerships with a wide range of individuals and organizations working on behalf of the river.**
- ❖ We continued our **community outreach**--listening, recording stories, offering talks and workshops at universities, high schools, elementary schools and for organizations like Amigos Bravos, as well as initiating community gatherings.
- ❖ We **presented an exciting series of events along the river** from May 15-21, 2013 entitled "One River." This five site "performance" consisted of five days of collaborative art, science and community engagement (visual art, poetry, performances, lectures, hikes, ceremonies, and more) at the Randall Davey Audubon Center/Nature Conservancy site, the New Mexico School for the Arts/Bishop's Pond/Rio Chiquito, San Isidro Crossing, La Bajada Village, and Cochiti Pueblo at the Rio Grande.

## ***Year One (Nov. 2011-May 2012)***

- ❖ Project artists Bobbe Besold, Valerie Martinez and Dominique Mazeaud spent 6 months **interviewing those who live along the river**--educators, city officials, environmentalists, artists, river-enthusiasts, ranchers, youth, farmers, tribal officials, Pueblo community members, and others. Our goal was to begin understand the Santa Fe River and the people who live there as an interconnected and mutually dependent system.
- ❖ In May, 2012, the team **walked the 54 mile length of the river** from the Upper Watershed (closed to the public since 1927) to the confluence at the Rio Grande. This rigorous 5 day/4 night pilgrimage served as a deep experience of and homage to the river's beauty, diversity, and endangerment.
- ❖ The walk also served as a unique **community gathering experience**--bringing students, educators, youth, families, adults, elders and others to the river. There were storytellers, art installations, community choir performances, river banners, schools of "river fish," puppeteers, and other forms of river art and engagement. Along the way we listened to watershed experts, students, families, and community members. We recorded interviews, captured audio, collected water samples, took photos and video, wrote poetry and kept daily accounts.

The *Rivers Run Through Us* **artist team** is Bobbe Besold, activist, Dominique Mazeaud, eco-artist and Valerie Martínez, collaborative artist, and former Poet Laureate for the City of Santa Fe. Current sponsors are *WildEarth Guardians, The Santa Fe Watershed Association, Littlelobe, Randall Davey Audubon Center and Sanctuary, the Santa Fe Art Institute, Amigos Bravos, the Center for Contemporary Arts, and the Western Hardrock Watershed Team.*

Rivers Run Through Us is a  
**Littlelobe** project  
[www.littlelobe.org](http://www.littlelobe.org)



art community social change

1/4" DREAMING WATER HOUSE RIVERS RUN THROUGH US

MATERIALS

1/4" 1/4" PLYWOOD

1/2" MOULDING

PLEXIGLASS FOR FRONT

EXTERIOR LATEX OR WATERPROOF STAIN OR SHELLAC

BOLTS  
SCREENS

+ WRITING (POEM, WATER STORY, DECLARATION, FACTS) (ETC)

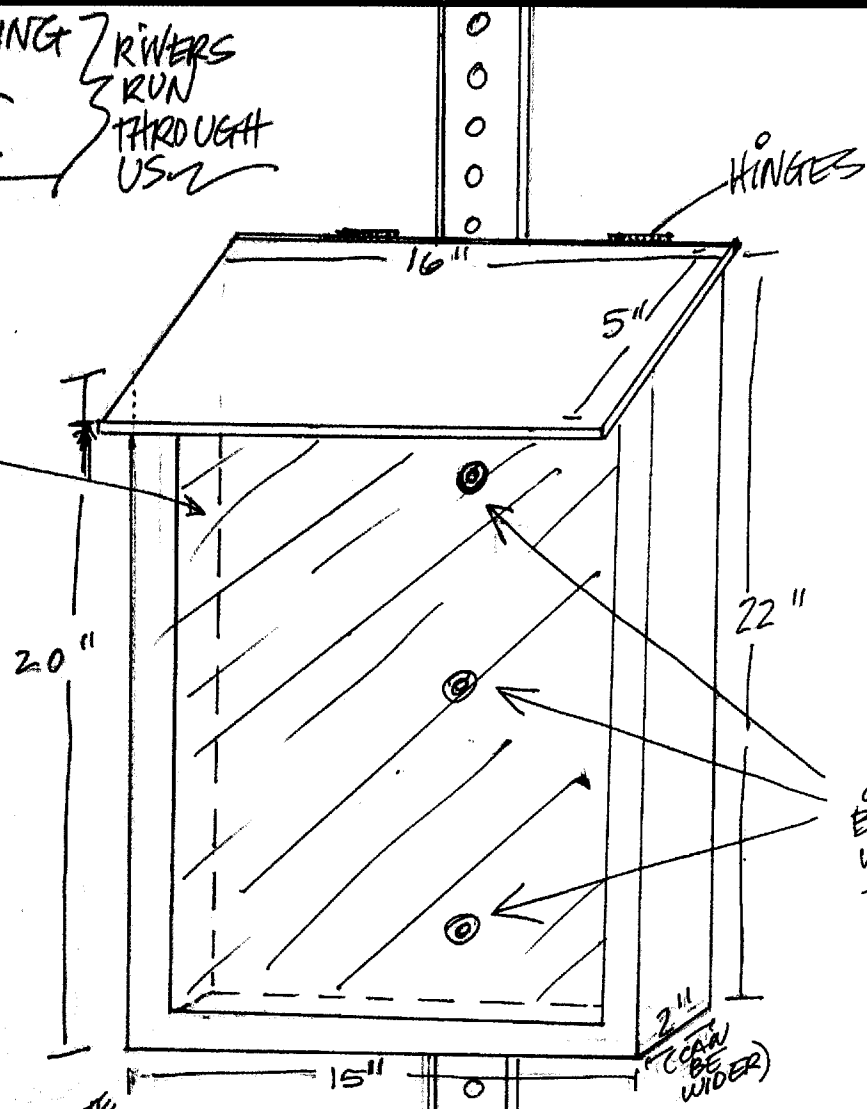

2-3 BOLTS WITH WASHERS THROUGH BACK PANEL ATTACHES TO A REGULAR SIGN POST

LITTLE ROOF (TO INDICATE HOUSE)

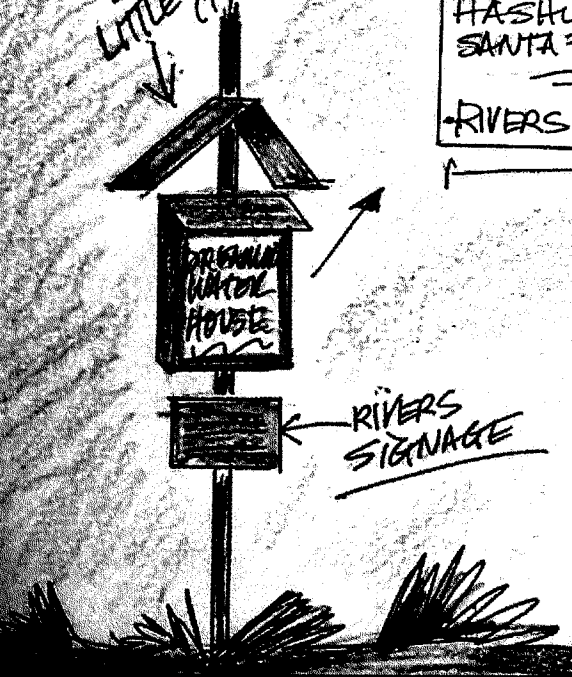

DREAMING WATER HOUSE  
HASHUK CHEENA (KERE)  
SANTA FE RIVER (ENGLISH)  
RIVERS RUN THROUGH US

IN ADDITION: CREDIT WHO POSTED THIS (LIKE VILLAGE OF AGUA FRIA, RANDALL DAVEY AUDUBON, ETC)

← SIGN POST